

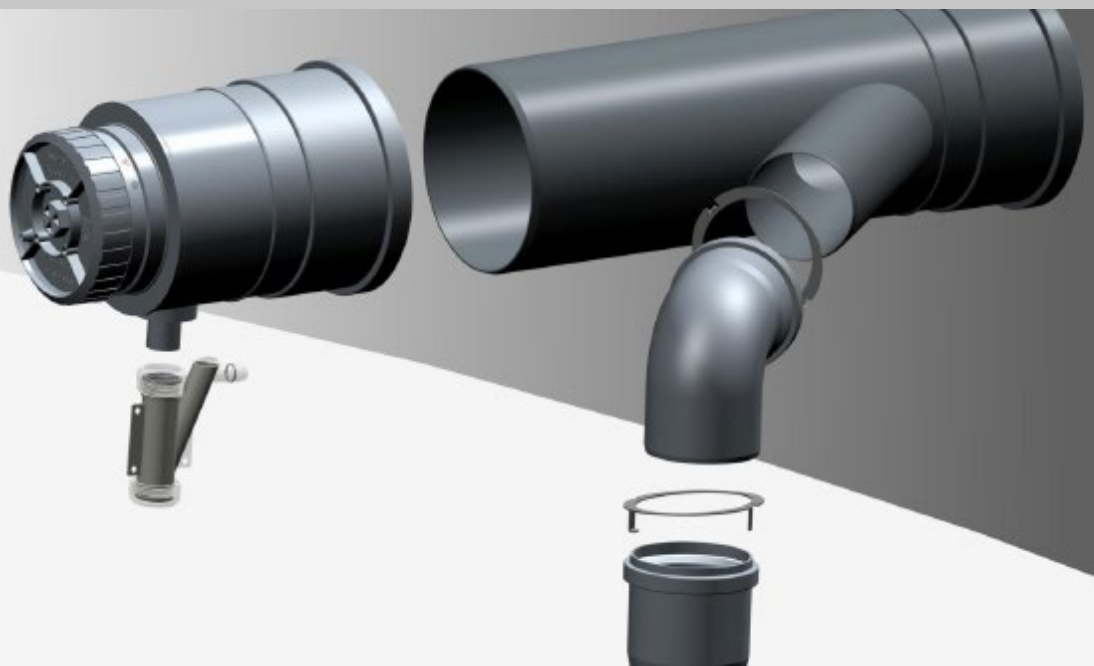

Centrotherm

Installation Instructions

InnoFlue® Single Wall Rigid, Flex, and Concentric Vent Systems



We are proud that InnoFlue® is tested and listed to:

UL 1738 | ULC-S636

- Examine all components for possible shipping damage prior to installation.
- **Do not mix products or instructions from multiple manufacturers.**
- Different manufacturers utilize different methods for joining vent sections. Proper joint assembly is essential for a safe installation. Follow these instructions exactly as written. Check integrity of joints upon completion of assembly.
- InnoFlue® must be free to expand and contract and must be supported in accordance with these instructions.
- Check for unrestricted vent movement through walls, ceilings, and roof penetrations.

Training
Videos



Further Resources

Contact Centrotherm



OEM Approvals

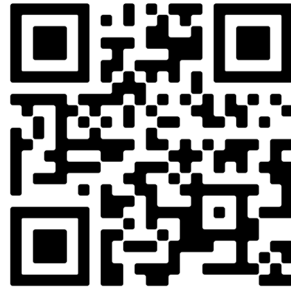

Training Videos

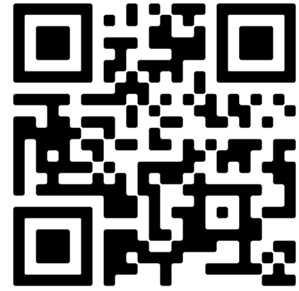

Adaptor Guide



Termination Options

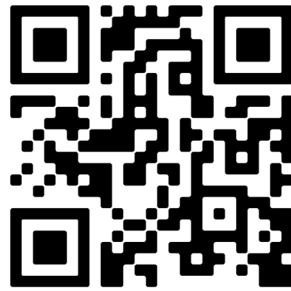

Social Media Links

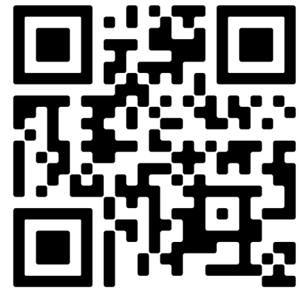

Quick Guide



Flex Quick Guide

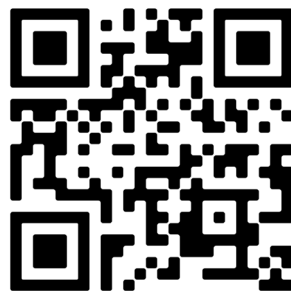

Condensate Guide

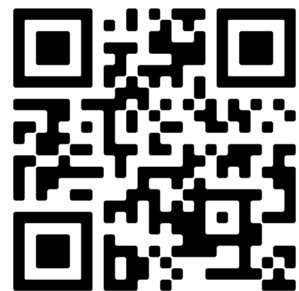

Table of Contents	
Introduction	4
General Installation Guidelines	4
Gasket Placement	5
Field Cutting	5
InnoFlue® SW Rigid	5
InnoFlue® Flex	5
Joint Connections	6
Vent Support	6
Horizontal	6
Vertical	6
Vent Pitch	7
InnoFlue® Condensate Drains	7
Vertical Installation	7
SW Rigid / Through Roof	8
SW Rigid Guy Wire Guidance	8
SW Rigid / Flexible Masonry Chimney or Chase	9
Vertical Termination	10
InnoFlue® Flex, Masonry Chimney	10
InnoFlue® SW Rigid, Masonry Chimney	10
InnoFlue® Flex into existing B-Vent	11
Multiple Vent Vertical Installation (Rigid or Flexible)	12
InnoFlue® Flex - 6" Diameter Installation	13
Single Wall Rigid - Horizontal Installation	14
Single Wall Rigid - Horizontal Termination	15
Horizontal Termination Configurations	16
InnoFlue® Flame & Smoke Spread Rating Assembly Instructions	17
Installation Instructions	17
InnoFlue® Fire Rated Wall/Ceiling Penetration Assembly	18
Concentric Installation Instructions	19
Concentric Adaptors	20
Concentric Vent Installation - Horizontal	20
Concentric Vent Installation - Vertical	21

INTRODUCTION

The InnoFlue® Vent System is manufactured from polypropylene. It has been ICC-ES evaluated to UL-1738 and ULC-S636 for use with Category II and IV (US) and Gas-Vent-BH, Class II C (Canada) Residential, Commercial, and Industrial gas fired appliances. InnoFlue® is UL-1738 & ULC-S636 rated for use with maximum flue gas temperatures of 230°F (110°C). NOTE: Centrotherm warrants InnoFlue® up to a sustained maximum flue gas temperature of 248°F (120°C). InnoFlue® is rated to a maximum vent pressure of .725 psi (5000 Pa) or 20" of water column.

As part of regular equipment maintenance, check for vent system integrity and blockage.

All installations must conform to all relevant Local, State and National codes. In the US: National Fuel Gas Code ANSI-Z223.1, NFPA 54, NFPA 211. In Canada: CAN/CGA-B149.1 or CAN/CGA-B149.2. Permits may be required before an installation can begin. Before installation, each vent component must be inspected for possible shipping damage and correct seal placement. These installation instructions must be read, understood, and complied with.

These installation instructions comply with UL-1738 and ULC-S636. Refer to the appliance manufacturer's installation instructions for appliance adaptors, terminations, maximum allowable vent length, and elbow equivalent lengths. For UL-1738 & ULC-S636 approved InnoFlue® components, consult the InnoFlue® catalog at www.centrotherm.us.com.

InnoFlue® vent components must be used throughout the entire vent system. Do not mix with other vent manufacturer's products.

GENERAL INSTALLATION GUIDELINES

Property damage, personal injury, or death can result if these instructions are not followed. They are a guide for professional installers generally familiar with the installation and maintenance of heating equipment and related vent systems.

- InnoFlue® can be installed at zero clearance to combustible materials.
- Masonry chimneys or existing B-vents can be used as passageways for InnoFlue® provided that no other appliances are or will be connected.
- Do not install InnoFlue® in a multiple flue chimney if one of the flues serves as an exhaust passage for a gas fire place or solid fuel burning.
- Appliances can be fired up immediately after an InnoFlue® vent system is installed and inspected.
- Free standing components (i.e. above the roof) may not exceed a maximum vertical height of 59" (1.5m) without additional support.
- Unless approved by the appliance manufacturer, only one appliance may be connected to a vent system.
- A Condensate Drain must be installed in the vent system as close to the flue outlet as possible unless the appliance is designed to manage condensate. Recommended to use additional drains on horizontal runs over 50'.
- All penetrations of fire rated walls/ceilings shall be sealed using fire stops that are approved for such use and must be installed according to this manual and the passive fire stop manufacturers installation instructions.
- When using InnoFlue® Flex, always refer to appliance installation instructions for maximum allowable length.
- Both InnoFlue® SW Rigid & Flex, systems expand and contract slightly during heating cycles and must be installed following these instructions.
- InnoFlue® can be painted. Use a paint that is recommended for use with polypropylene, such as Rust-Oleum or Krylon. Before painting, remove any ink markings on vent with acetone (or equivalent) and then apply an adhesion promoter that is specifically recommended for use with polypropylene. Reattach label to InnoFlue vent after paint has dried.
- Use of Centrotherm supplied supports is strongly recommended. In instances where Centrotherm supports are not suitable, field supplied supports that are of clam shell design and have a minimum threaded rod diameter of 5/16" (8mm) are permissible.
- InnoFlue® Flex can be sloped a maximum of 45° off of vertical, i.e. minimum of 45° off of horizontal.
- If InnoFlue® Flex is installed when the outside temperature is less than 32°F (0°C), install liner from bottom of chase. Keep InnoFlue® Flex greater than 32°F (0°C) during installation.
- All diameters of InnoFlue® SW Rigid product (gray and black) are UV stabilized and can be installed outside of a building. In diameters 2", 3", & 4" black components are available for enhanced performance but are not required.
- Do not use spray foam or mortar on InnoFlue® SW Rigid on Flex.
- For exterior components only, a single stainless-steel screw may be used to fix direction of vent.
- Rain Caps are not required (refer to local codes).
- Due to insulating properties of InnoFlue® polypropylene material additional insulation is not required. For installations that require flame spread index and smoke developed index of <25 / <50 refer to InnoFlue® Flame & Smoke Spread Rating Assembly Instructions. For outdoor installations in extreme cold weather environments mineral wool and aluminum cladding can be used.
- InnoFlue® cannot be directly buried in the ground. If application requires underground installation, InnoFlue® must be sleeved with a larger diameter pipe that is suitable for direct bury applications. InnoFlue® must be supported, pitched, and able to expand/contract within the sleeve.

GASKET PLACEMENT

- Gaskets are factory installed in all InnoFlue® components.
- If a gasket is missing or damaged, it must be replaced by a correctly sized, Centrotherm supplied gasket.
- Make sure gasket bead and gasket itself are clean, then insert the new gasket in correct orientation as shown.
- Gasket must fit evenly within the gasket bead.

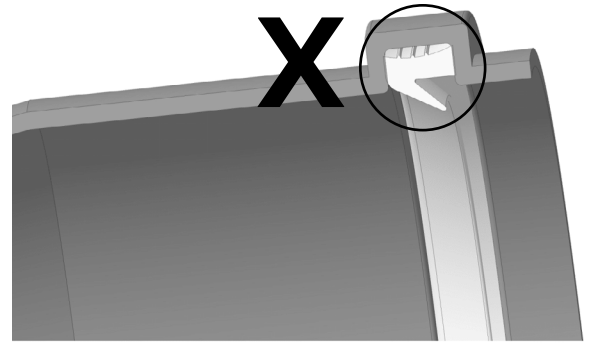
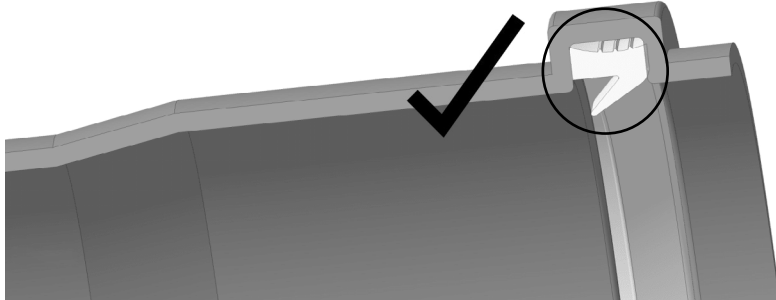

FIELD CUTTING INNOFLUE® SW RIGID VENT LENGTHS

- Use trade tools such as a hack saw to create a perpendicular, clean cut.
- Deburr cut end so that damage to the gasket is avoided. Use Reed Manufacturing DEB4 or equivalent.
- Remove debris from inside the pipe prior to assembly.
- Chamfering vent is optional but will ease installation.

FIELD CUTTING INNOFLUE® FLEX

- 3" / 4" InnoFlue® Flex feature rigid sections. At base of the flex pipe, leave a full rigid section for connection to InnoFlue® SW Rigid.
- Use trade tools such as a hack saw to create a perpendicular, clean cut at the bottom of the rigid section.
- 2" InnoFlue® Flex is corrugated. Use a razor knife to cut. Only cut inside corrugation recess – see image below
- Connect 2" InnoFlue® Flex to SW Rigid using SW/Flex adaptor
- Deburr cut end so that damage to the gasket is avoided. Use Reed Manufacturing DEB4 or equivalent.
- Remove debris from inside the pipe prior to assembly.

CAUTION: Damaged gaskets can cause leakage of dangerous levels of carbon monoxide or property damage due to condensate leaks!

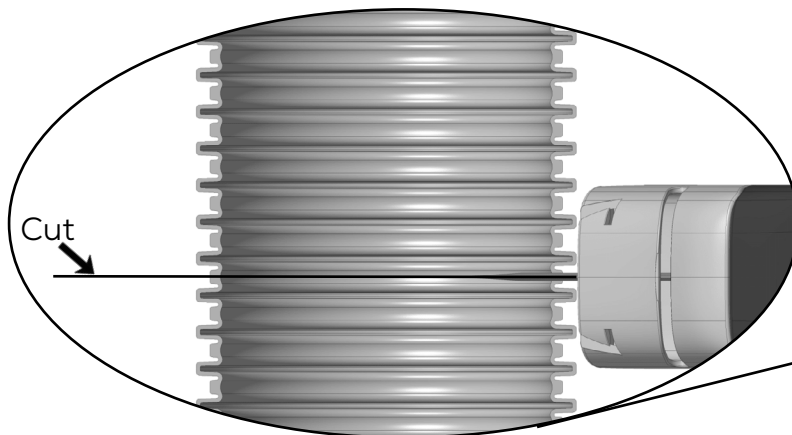

InnoFlue® SW Rigid

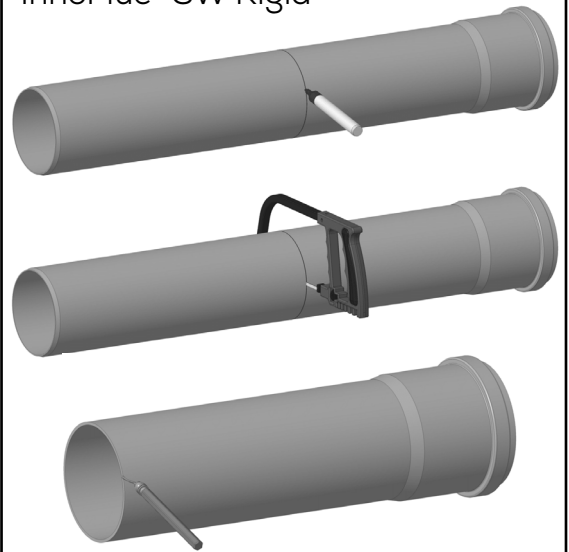

InnoFlue® Flex (3" & 4")

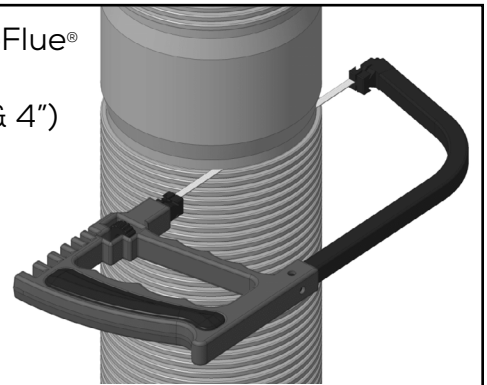

InnoFlue® Flex (2")

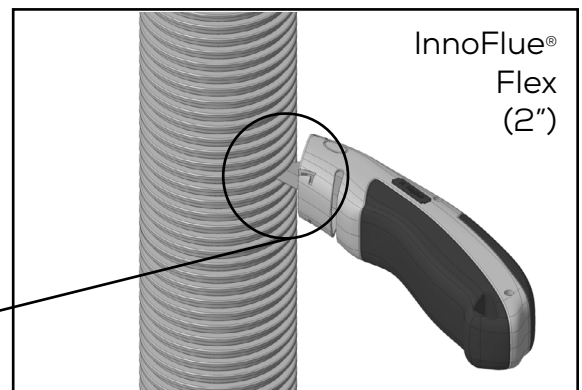

JOINT CONNECTIONS

- InnoFlue® components are factory labeled displaying a flow arrow. This arrow represents exhaust flow and must point towards the termination (away from the appliance).
Exception: when using InnoFlue® for air intake the flow arrow direction is not applicable
- Each female-end of every InnoFlue® vent length or component features a factory installed gasket. Before assembly, make sure gaskets are in place correctly (see Gasket Placement)
- For Horizontal sections measure the depth of the female socket. Mark the male-end of each component 1/4" less than the depth of the female socket from its end.
- Place a thin layer of Centrocerin, a water-based lubricant, onto the male end of component 2 for ease of assembly.
Note: Water can be used as a lubricant.
- Slip a Connector Ring over the male end of component 2 so that it can grip the gasket bead of component 1.
- Push and twist male end until properly seated in component 1, aligning the mark with the top of the female end.
- Clip the Connector Ring onto the gasket bead to secure the two components to each other. Standoff leg will rest on top of gasket bead as shown.

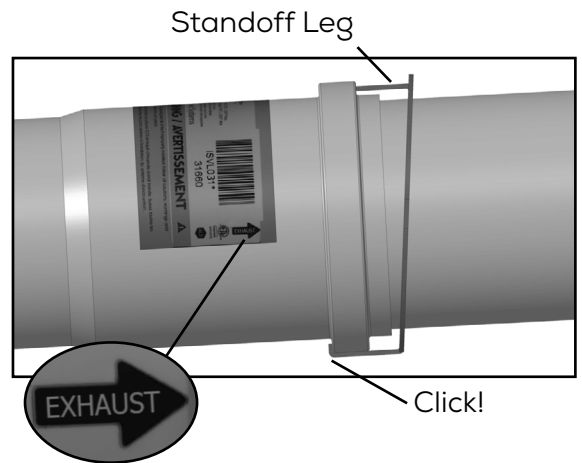
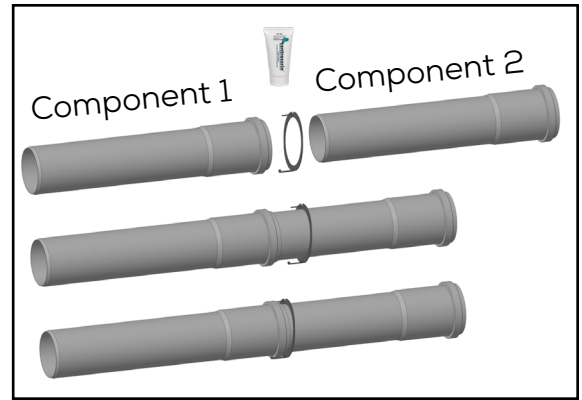

NOTE:

To meet requirements of ULC-S636 & UL-1738, only InnoFlue® Vent Systems of 2", 3", and 4" diameters must utilize Connector Rings.

NOTE:

Screwdriver can be used to assist with connector ring installation if needed.

VENT SUPPORT - HORIZONTAL

- Use only InnoFlue® SW Rigid vent lengths for horizontal vent configurations.
- Install Support Brackets onto solid ceiling joists or surfaces.
- Space Support Brackets no more than 39" (1m) apart.
- Use additional Support Brackets at directional changes such as Elbows or Tee sections as needed. Recommended to support within X in. of direction change depending on vent length diameter.

VENT SUPPORT - VERTICAL

- Use only InnoFlue® SW Rigid vent lengths for vertical, wall mounted vent configurations.
- Install Support Brackets onto solid wall studs or surfaces.
- Space Support Brackets no more than 78" (2m) apart.
- Use additional Support Brackets at directional changes such as Elbows or Tee sections as needed. Recommended to support within X in. of direction change depending on vent length diameter.

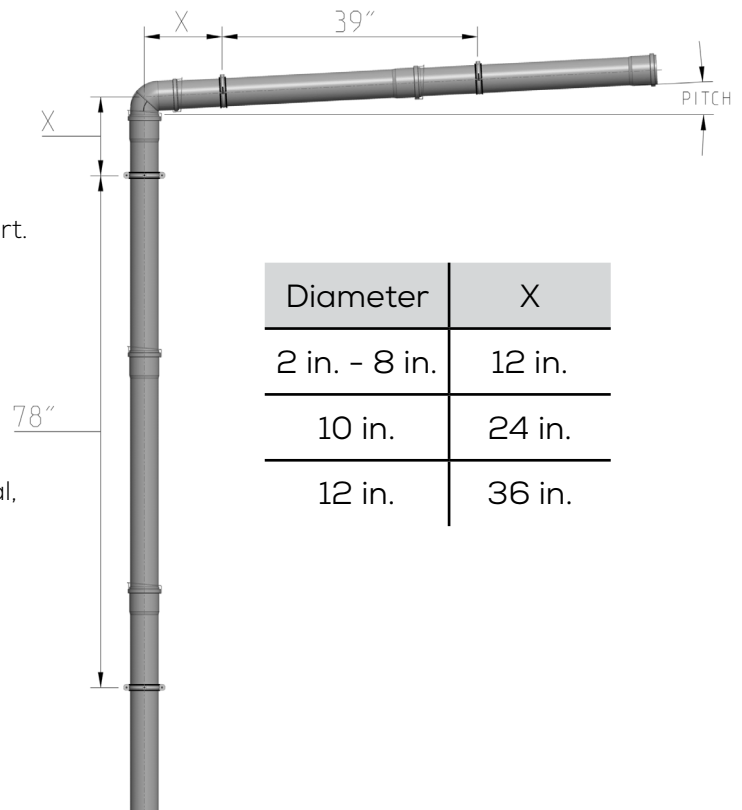

VENT PITCH

- Male ends of all components must point and pitch back towards the appliance to assure free condensate flow to the Condensate Drain of the appliance or vent system.

Diameters 2", 3", 4", & 6"

- Vent Lengths installed in a horizontal configuration of diameters 2", 3", 4", and 6" must be pitched towards the appliance and at an angle of no less than 1° or 1/4 in/ft (2.1 cm/m). If increasing to 8", 10", or 12" diameter, that section must be pitched at an angle of no less than 3° or 5/8 in/ft.

Diameters 8", 10" & 12"

- Vent Lengths installed in a horizontal configuration of diameters 8", 10", or 12" must be pitched towards the appliance and at an angle of no less than 3° or 5/8 in/ft (5.2 cm/m).

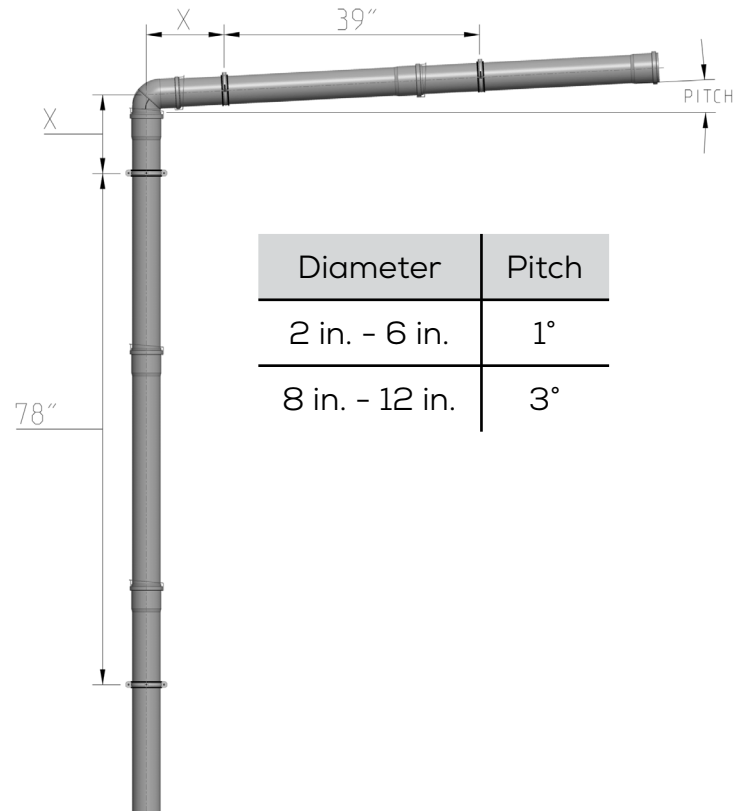

INNOFLUE® CONDENSATE DRAINS

InnoFlue® Siphons

- When using a Condensate Drain with the InnoFlue® Siphon, slide it on to the Condensate Drain nipple and tighten, attach a 5/8" (16mm) I.D. plastic tube to its outlet and lead it to an appropriate condensate disposal location.
- Fill this siphon with water before application start-up.

Tube Siphons

- As an alternative, use a 1 1/4" (32mm) I.D. plastic tube to create and secure a loop (siphon), fill loop with water, then affix the tube onto the Condensate Drain Nipple and lead tube to an appropriate condensate disposal location such as a sanitary sewer drain.
- Consult appliance manufacturer's instructions for additional requirements regarding condensate drains.

InnoFlue® Siphon (preferred)

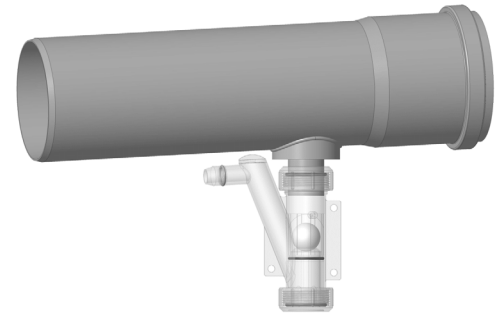

Tube Siphon

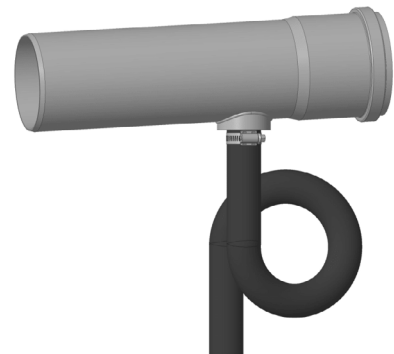

VERTICAL INSTALLATIONS (SW RIGID / THROUGH ROOF)

- InnoFlue® can be installed at zero clearance to combustibles materials.
- Install the appliance adaptor as approved by the appliance manufacturer.
- Add vent lengths, elbows and condensate drain(s) as needed to reach the final vertical vent run.
- If horizontal run is more than 39" (1m), install Support Brackets onto solid ceiling joists or surfaces.
- Pitch horizontal portion of the vent system (see Vent Pitch)
- Install a Support Bracket at any directional change (see Vent Support - Horizontal Vertical)
- On vertical runs, install Support Brackets no more than 78" (2m) apart.
- Install Support Brackets onto solid wall studs or surfaces.
- Opening in roof deck should be cut slightly larger than the vent diameter.
- Terminate standard vent pipe so that the top female end remains below the roof flashing.
- Insert End Pipe into the top of the standard vent pipe.
- Slip an approved Roof Boot (such as Oatey) or custom flashing over the End Pipe.
- Follow the instructions of the Flashing manufacturer to correctly seal the roof penetration.
- Insert a Bird Screen into End Pipe (per local code).
- Vertical termination greater than 59" (1.5m) beyond the roof line must be supported by braces or guy wires.

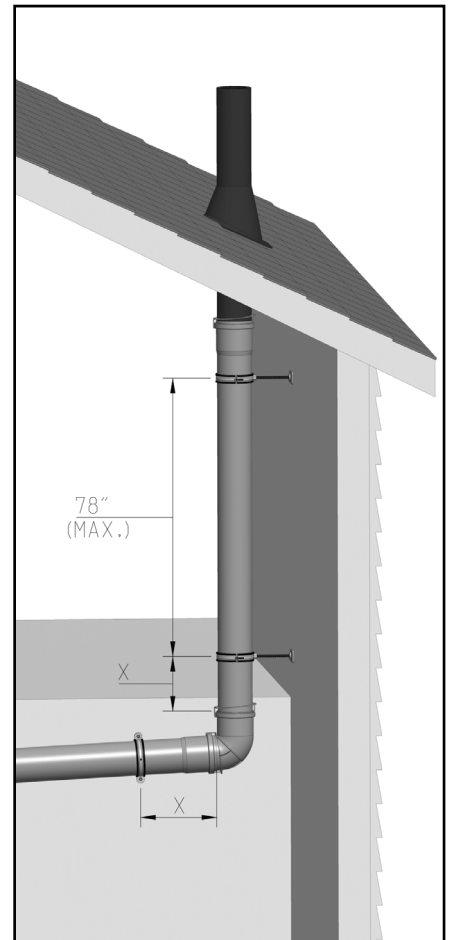

SW RIGID GUY WIRE GUIDANCE

- Use of field-sourced guy wire and clamps can be used in conjunction with InnoFlue® for required vertical support, Centrotherm supplied clamps can also be used.
- Refer to local code for support distances when required.

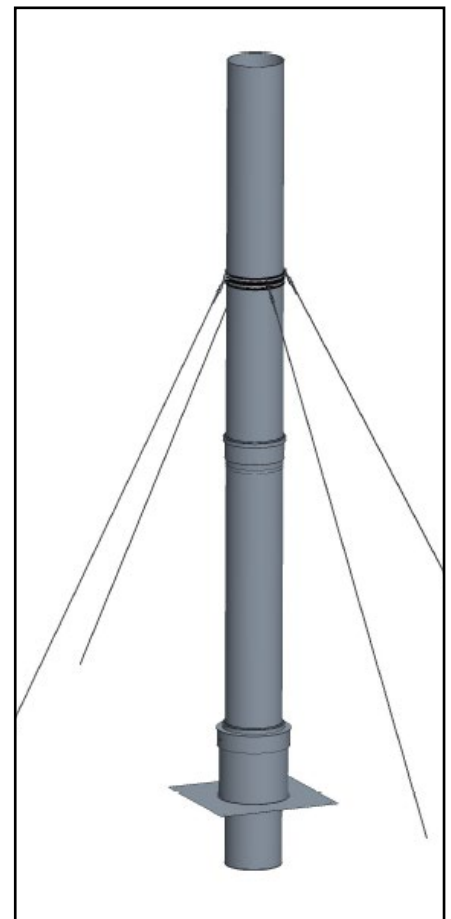
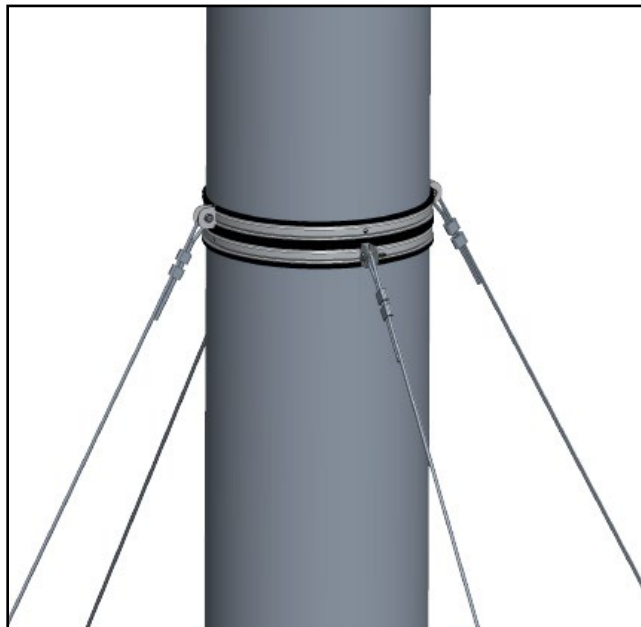

VERTICAL INSTALLATIONS (SW RIGID OR FLEXIBLE / MASONRY CHIMNEY OR CHASE)

- When using a masonry chimney as a passageway for InnoFlue® SW Rigid or Flex, the chase must be structurally sound and free of debris or obstructions.
- If only supported with a Base Support at the bottom, the maximum continuous vertical vent length for a rigid InnoFlue® vent system cannot exceed 164' (50m).
- If only supported with a Base Support at the bottom and a standard chimney cover at the top, the maximum continuous vertical vent length for a flexible InnoFlue® vent system cannot exceed 98' (30m).
- Multiple InnoFlue® vent or air intake systems can be installed into one chase.
- Affix Spacers onto each vent or air intake (offset them), then pull or lower them individually or bundled into the chase.
- To avoid condensate pooling and damage to vent, InnoFlue® Flex offsets cannot exceed 45° off the vertical. Multiple offsets are allowed in a chase.
- Both InnoFlue® SW Rigid and Flex expand slightly during normal operation. Rigid pipe can expand upwards through the Chimney Cover, Flex slightly diverts from vertical.
- Install a Base Support bracket just below the entry point into the chase.
- When measuring for Flex length from the Base Support, add at least 2' above the chimney top.
- Measuring from the Base Support, attach Spacers at intervals of 78" (2m) or less to the rigid or flex pipe.

NOTE: Spacers serve to keep InnoFlue® SW Rigid or Flex away from rough surfaces to avoid damage to the pipe during installation or normal operation. They do not have a support function. Attach Spacers to the pipe even if the chase is larger than the reach of the Spacers.

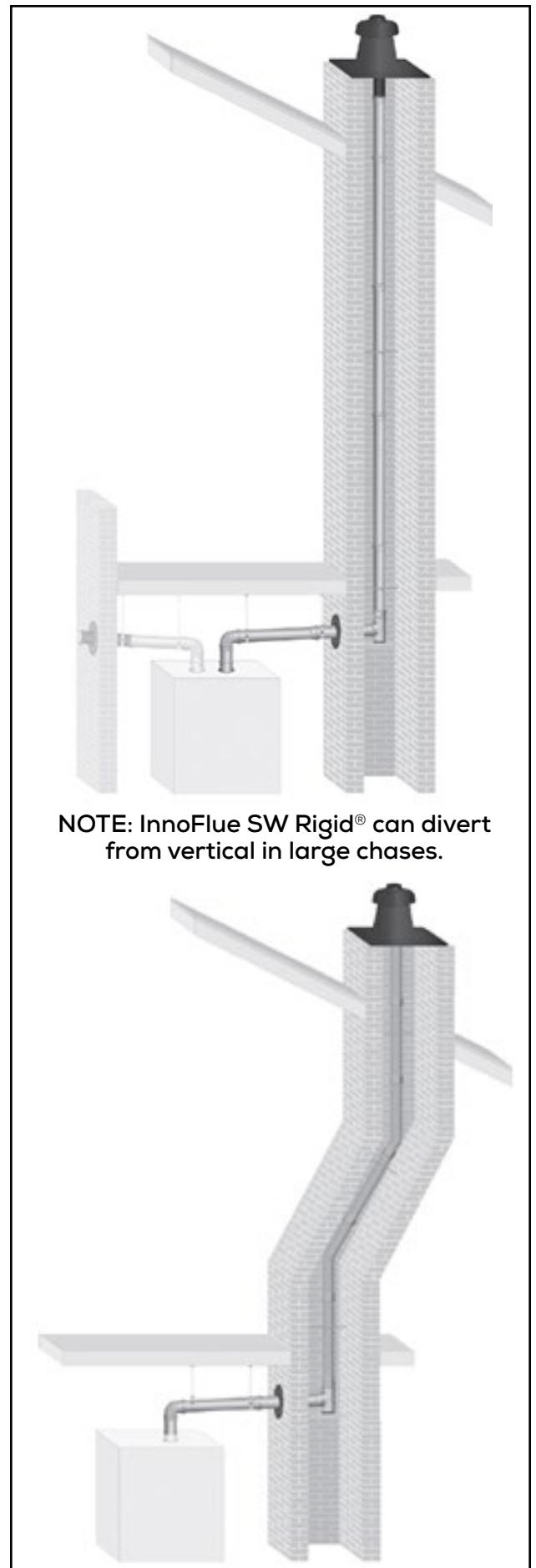
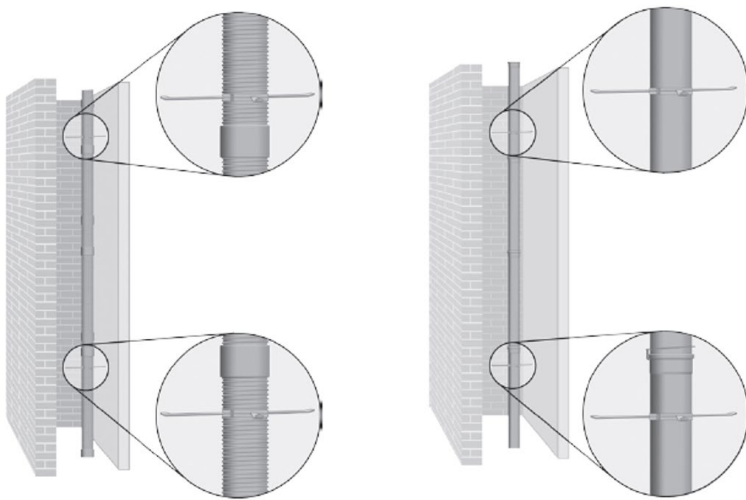

NOTE: InnoFlue SW Rigid® can divert from vertical in large chases.

VERTICAL INSTALLATIONS (SW RIGID OR FLEXIBLE / MASONRY CHIMNEY OR CHASE) (CONT.)

- Pull assembled rigid sections (see Joint Connections) or InnoFlue® Flex up to the top (lowering from the top is an option)
- It is recommended to use guy-wire or cable when lowering long runs of rigid down a chimney or chase.
- For 3" and 4" diameter InnoFlue® Flex, cut the liner at the bottom of the nearest rigid section which fits into the female end of any InnoFlue® component. For 2" InnoFlue® Flex, attach a SW Rigid to Flex Coupler. (See Field Cutting InnoFlue® Flex).
- Slip a Connector Ring over the bottom of the vent pipe (see Joint Connections).
- Seat male end of the rigid vent pipe or the rigid section of InnoFlue® Flex into the Base Support (see Joint Connections).
- Click the Connector Ring onto the base support.
- Insert Stem of base support into base support bracket.
- Install lock washer onto stem. From the Base Support, make the connection to the appliance with rigid components, following Horizontal Installation instructions.
- Use a Wall Plate to seal masonry around vent pipe.
- Do not use spray foam or mortar on InnoFlue® SW Rigid on Flex.

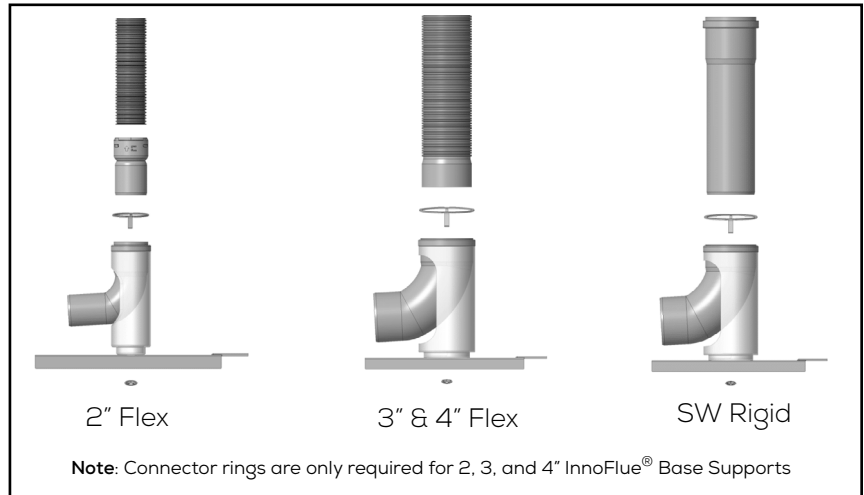

VERTICAL TERMINATION (INNOFLUE FLEX, MASONRY CHIMNEY)

- InnoFlue® Flex should now extend about 2' above the masonry.
- Slip the Chimney Cover over Flex pipe.
- Anchor the Chimney Cover to the masonry with screws (provided) and silicone. Pre-drill masonry with 3/16" \varnothing (5mm \varnothing) size bit.
- Slip the Flex End Pipe Locking Ring over the flex pipe and seat into slot at the top of the Chimney Cover.
- Trim Flex pipe flush with Flex End Pipe Locking Ring.
- Twist Flex End Pipe into the top of the Chimney Cover/ Flex Pipe/Locking Ring.
- Push Cap over End Pipe until it snaps in place.
- Insert a Bird Screen into Flex End Pipe (per local code).

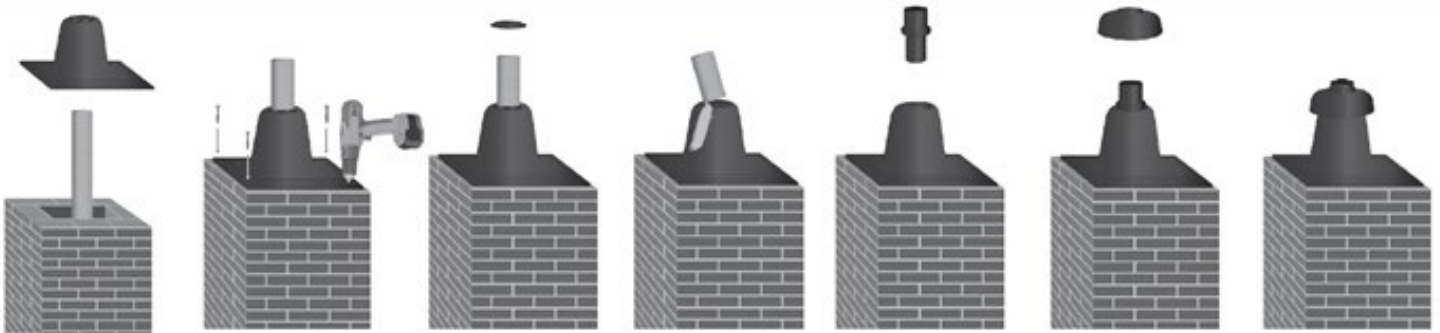

VERTICAL TERMINATION (INNOFLUE SW RIGID, MASONRY CHIMNEY)

Terminate standard vent pipe so that the top female end remains below the top of the Chimney Cover.

- Insert End Pipe into the top of the standard vent pipe.
- Slip the Chimney Cover over End Pipe.
- Anchor the Chimney Cover to the masonry with screws (provided) and silicone. Pre-drill masonry with 3/16" \varnothing (5mm \varnothing) size bit.
- Insert a Bird Screen into End Pipe (per local code).

VERTICAL TERMINATION (INNOFLUE® FLEX, INTO EXISTING B-VENT)

When using an existing B-vent system as a passageway for InnoFlue® Flex, follow the general instructions for Vertical Installation through a masonry chimney, then terminate the vent system as follows:

Bottom Termination (InnoFlue® Flex, B-Vent)

- Remove the Rain Cap from the B-Vent chase top. Remove horizontal B-vent sections back to the vertical support box.
- Make sure the B-vent between its new bottom and top is in good condition and unobstructed throughout.
- Install InnoFlue® Flex through the B-Vent leaving 2' flex above top of B-Vent and temporarily secure at both ends.
- Assemble Base Support and InnoFlue® Flex as per Vertical Installation through a masonry chimney.
- Lower the Base Support so that its stem is securely seated into the hole of the B-Vent Support Bracket. Install lock washer onto stem.
- Use two fasteners per side to affix the B-Vent Support Bracket to the ceiling joists.
- From the Base Support, make the connection to the appliance with rigid components, following *Horizontal Installation Instructions*.

Top Termination (InnoFlue® Flex, Universal B-Vent)

- Remove existing B-Vent Cap. If B-Vent is larger than 6" diameter a B-vent reducer may be installed or a custom cover from Centrotherm can be used.
- InnoFlue® Flex should now extend about 2' above the B-Vent chase.
- Slip the B-Vent Cover over flex pipe.
- Anchor the Universal B-Vent Inner Cap to the B-Vent to the B-Vent using three of the 1/2" screws provided.
- Slip the Flex End Pipe Locking Ring over the flex pipe and seat into slot at the top of the B-Vent Cover.
- Trim Flex pipe flush with Flex End Pipe Locking Ring.
- Twist Flex End Pipe into the top of the B-Vent Cover/ flex pipe locking ring.
- Push Universal B-Vent Exterior Cap over the end pipe until bottomed out. Fasten to the Inner cover using three of the 1/2" screws provided.
- Insert a Bird Screen into Flex End Pipe (per local code)
- For more detailed instruction refer to *Installation Instructions for Universal B-Vent Cap*

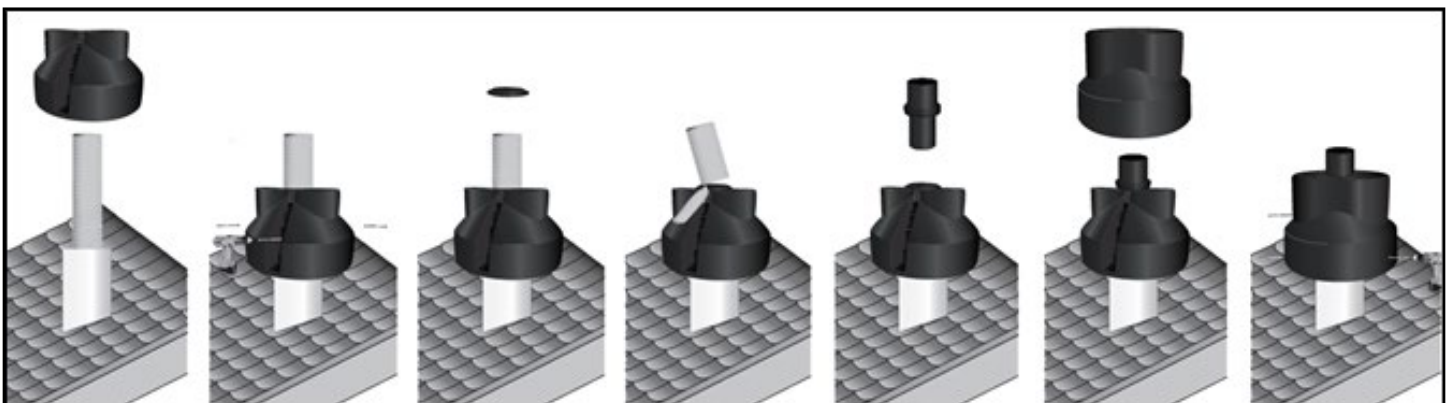
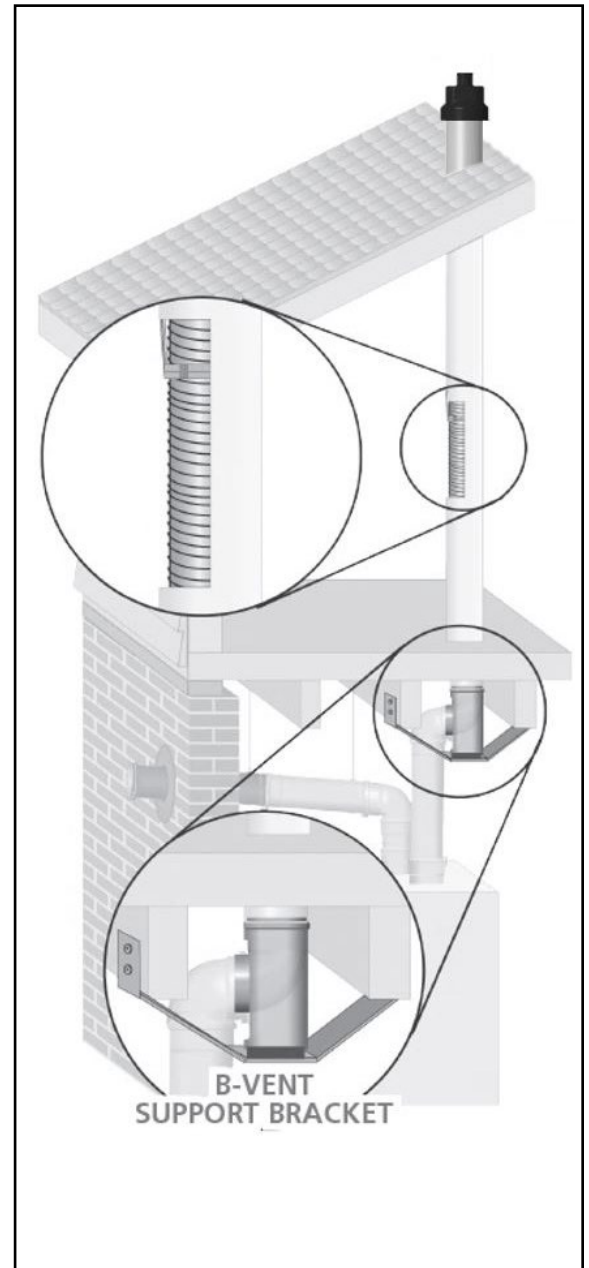

MULTIPLE VENT VERTICAL INSTALLATION (RIGID OR FLEXIBLE, THROUGH A MASONRY CHIMNEY OR EXISTING B-VENT)

Refer to (VERTICAL INSTALLATIONS (SW RIGID OR FLEXIBLE / MASONRY CHIMNEY OR CHASE)) & (VERTICAL TERMINATION (INNOFLUE® FLEX, INTO EXISTING B-VENT)) for general installation instructions through a Masonry Chimney or B-Vent.

Masonry Chimney Rigid & Flex

- Install the InnoFlue® Base Supports (1) to the base of the chimney.
- Lower assembled InnoFlue® Rigid (2) sections (see Joint Connections) or InnoFlue® Flex (3) down from the top of the chimney (pulling from the bottom is also an option).
- Install InnoFlue® spacers (4) to both the exhaust and intake vents vertically offset from one another while lowering.
- When using InnoFlue® Rigid (2) or InnoFlue® Flex (3) install to the base support elbow (see Vertical Installations (SW Rigid or Flexible / Masonry Chimney or Chase)).
- If using InnoFlue® Flex (3) for intake, attach an InnoFlue flex to single wall coupler (5) to the end of the flex. Using a field supplied hose clamp (6) (tightened below the gasket relief) and strap (7) support the coupler (5) to the top of the chimney.
- Insert an end pipe (8) into the exhaust socket and terminate using a chimney cover (9) (see Vertical Termination [InnoFlue SW Rigid, Masonry Chimney]).

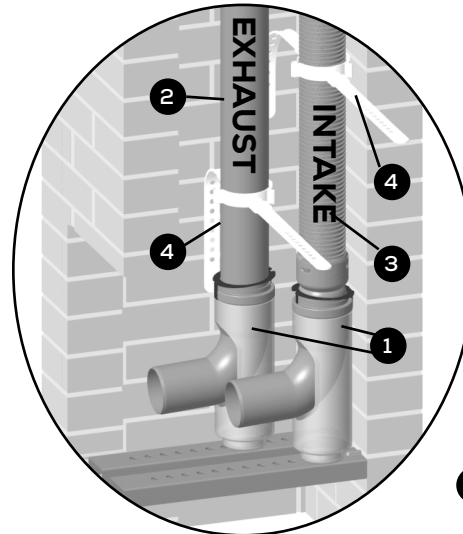
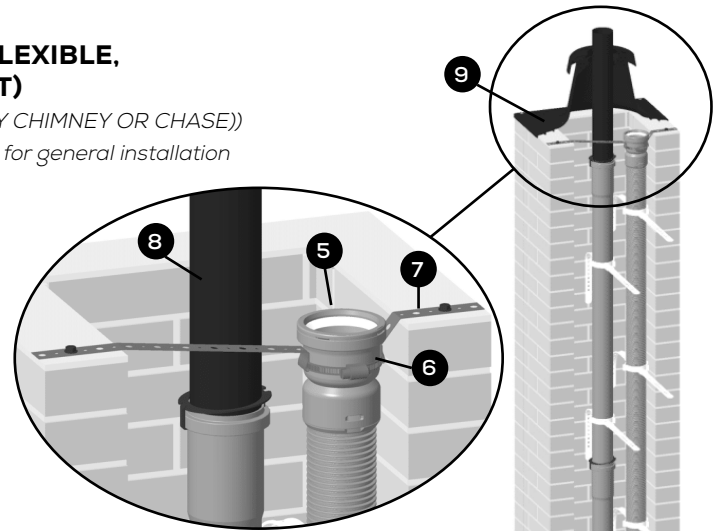

Existing B-Vent Rigid & Flex Termination

- Install InnoFlue® B-Vent Support Brackets (10) and Base Supports (1) (see Bottom Termination (InnoFlue Flex, Into Existing B-Vent)).
- When multiple vents are required to face the same direction, the use base support brackets included with each InnoFlue® Base Supports (1) and secure to structure.
- Lower assembled InnoFlue® Rigid (2) sections (see Joint Connections) or InnoFlue® Flex (3) down from the top of the B-Vent (pulling from the bottom is an option).
- Install InnoFlue® spacers (4) to both the exhaust and intake vents vertically offset from one another while lowering.
- When using InnoFlue® Rigid (2) or Flex (3) install to the base support elbow (see Vertical Installations [SW Rigid or Flexible / Masonry Chimney or Chase]).
- If using InnoFlue® Flex (3) for intake, attach an InnoFlue flex to single wall coupler (5) to the end of the flex. Using a field supplied hose clamp (6) (tightened below the gasket relief) and strap (7) support the coupler to the top of the B-Vent.
- Insert an end pipe (8) into the exhaust socket and terminate using a chimney cover (11) (see Vertical Termination [InnoFlue Flex, Into Existing B-Vent]).

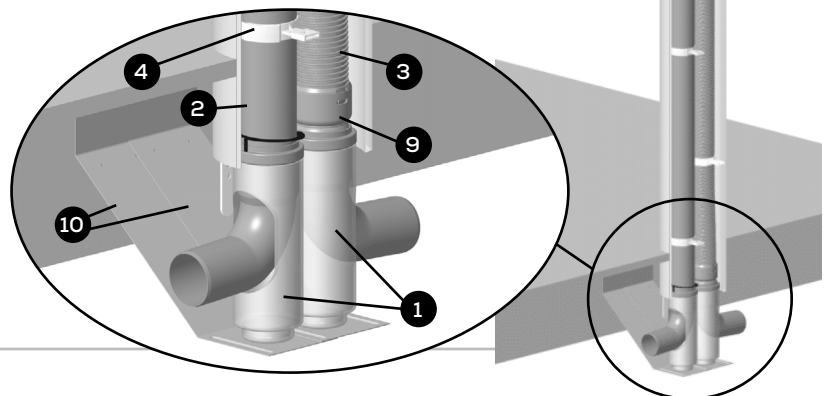
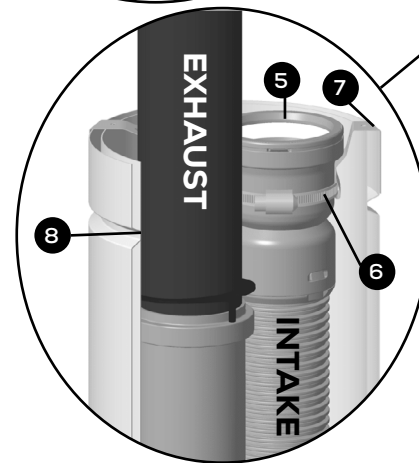

Note: For installations requiring a custom chimney or b-vent cover, contact customer service.

INSTALLATION OF INNOFLUE FLEX - 6 IN.

- See Vertical Installations (SW Rigid or Flexible / Masonry Chimney or Chase) for general flex installation guidelines.
- Install the InnoFlue® 6" Base Support (1) to the base of the chimney.
- Measure the distance from the InnoFlue® 6" Base Support (1) to the termination location to calculate the required length of 6" InnoFlue® flex needed.
- At the top of the chimney lower an InnoFlue 6" flex variable vent length (2) into the chimney (Guy wire can be used to aid in lowering flex vent).
- Attach an InnoFlue® 6" flex spacer (3) to the rigid section of the top socket of the InnoFlue® 6" flex variable vent length (2)
- Insert the male of an InnoFlue® 6" flex vent length (4) to the socket of the initial InnoFlue® 6" flex starter variable length (2) and turn clockwise until fully threaded.
- Attach an InnoFlue® 6" flex spacer (3) to the rigid section of the socket of the InnoFlue® 6" flex vent length (4).
- Continue adding InnoFlue® 6" flex vent lengths (4) and InnoFlue® 6" flex spacers (3) until the initial InnoFlue® 6" flex variable vent length (2) has reached the InnoFlue® 6" Base Support (1) and the top of the stack is less than 1 meter from the top of the chimney.
- Down at the InnoFlue® 6" Base Support (1) slide an InnoFlue® 6" connector ring (5) up the male of the initial InnoFlue 6" flex variable vent length (2), then insert into the female socket of the InnoFlue® 6" Base Support (1).
- At the top of the flexible InnoFlue® vent system, install an InnoFlue® 6" flex variable vent length (2) into the socket of the last InnoFlue® 6" flex vent length (4).
- At the termination cut InnoFlue® 6" flex variable vent length (2) 2" (max) above the top of chimney. Ensure cut is perpendicular and clean.
- Connect InnoFlue® 6" flex suspension ring (6) to location (7) of the InnoFlue® 6" flex variable vent length (2). Using the metal arms secure the InnoFlue® 6" flex suspension ring (6) to the top of the chimney. Ensure the top of the flex pipe is at max. 2" above the top of the chimney.
- Fully Insert an InnoFlue® 6" end pipe (8) into cut socket of InnoFlue® 6" flex variable vent length (2). *Can use InnoFlue® Rigid vent length when extended length is required.
- Install InnoFlue® 6" chimney cover (9) over the InnoFlue® 6" end pipe (8) and fasten to the chimney.

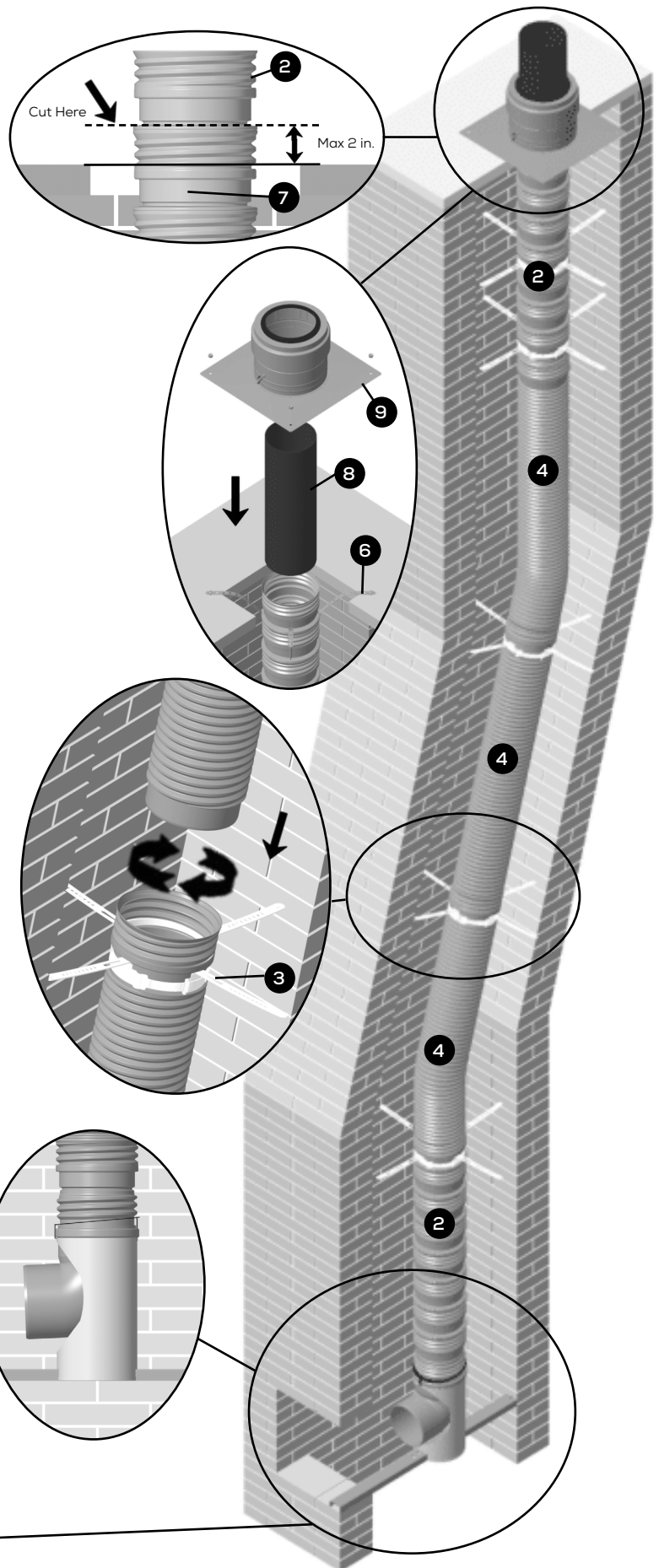

HORIZONTAL SINGLE WALL, THROUGH THE WALL INSTALLATION

- Total equivalent vent length may not be greater than specified in the appliance manufacturer's instructions.
 - Find the best suitable spot to penetrate the wall based on ANSI Z223.1/NFPA 54 specifications. Consult drawing table for permitted Vent Terminal (V) locations.
 - As InnoFlue® can be installed at zero clearance to combustibles, cut a hole (key hole saw) slightly larger than the OD of the gasket bead.
 - For horizontal vent configurations, use InnoFlue® SW Rigid components only.
 - For air intake, InnoFlue® SW Rigid or Flex may be used.
 - If horizontal run is more than 39" (1m), install Support Brackets onto solid ceiling joists or surfaces.
 - Pitch any horizontal portion of the vent system towards the appliance at the angle specified in the Vent Pitch section.
 - Install the appliance adaptor as approved by the appliance manufacturer.
 - Add vent lengths, elbows and condensate drain(s) as needed to reach the wall penetration (see Joint Connections).
 - Seal the wall area around the vent with silicone.
-

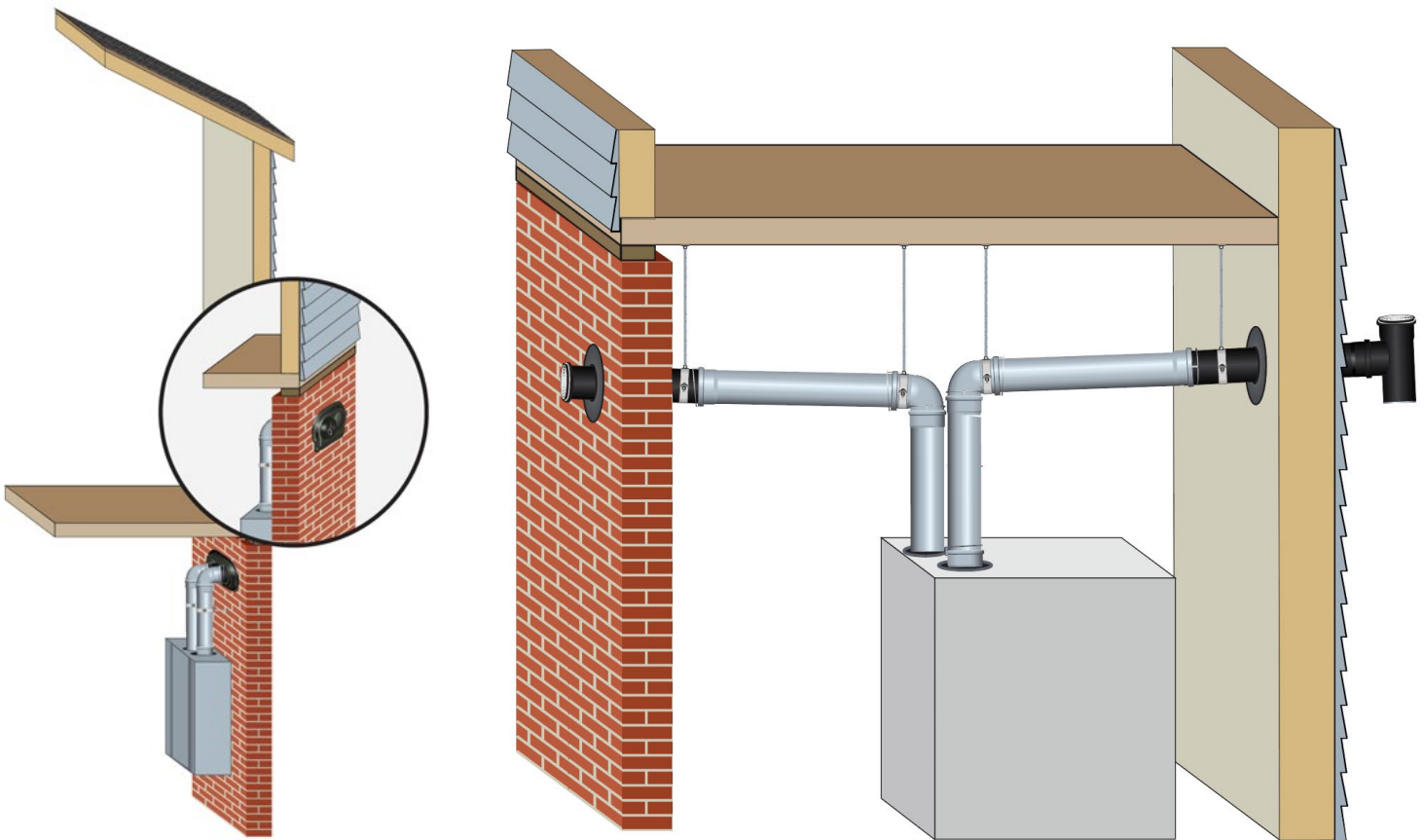

HORIZONTAL VENT TERMINATIONS

- If going straight through a wall, the vent cannot extend more than 12" (305mm) from the wall's exterior.
- Termination Tees, velocity cones, 45°, or 90° elbows may be used to direct flue gases in desired directions.
- Snorkel configurations may be used when wall penetration does not meet "V" location specifications.
- Any vertical portion of a vent or air intake that is outside the building must be secured to the building with Support Clamps.
- Install Bird Screens into any exterior vent or air intake opening (optional).
- The Concentric Wall Termination allows for a single wall penetration.
 - ◊ Install a Twin Pipe to Concentric Adaptor to co-locate vent and air intake inside the building.
 - ◊ Add a Concentric Wall Termination to go through the wall.
 - ◊ See Concentric section for installation instructions.

CAUTION

Maintain 12" of clearance above the highest anticipated snow level or grade or whichever is greater. Please refer to your local codes for the snow level in your area.

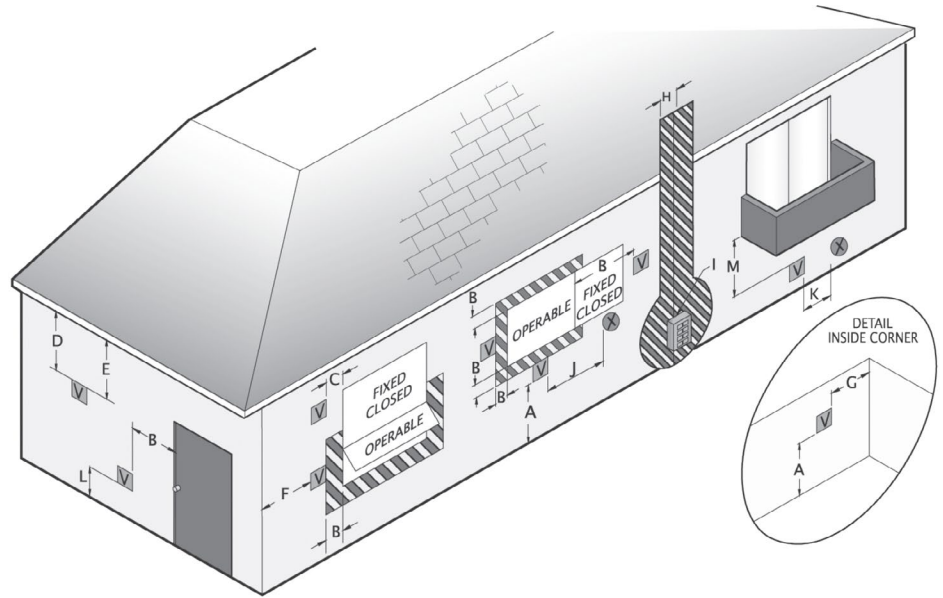

V VENT TERMINAL PERMITTED AREA WHERE TERMINAL IS NOT PERMITTED AIR SUPPLY INLET

REF	DESCRIPTION	U.S.A.	CA
A	Clearance above grade, veranda, porch, deck, or balcony	12 in.	12 in (30 cm)
B	Clearance to window or door that may be opened	<ul style="list-style-type: none"> • 6 in. Appliances ≤ 10 kBtu/hr • 9 in. Appliances > 10 & ≤ 50 kBtu/hr • 12 in. Appliances > 50 & ≤ 150 kBtu/hr 	<ul style="list-style-type: none"> • 6 in. (15 cm) Appliances ≤ 10 kBtu/hr (3 kw) • 9 in. (23 cm) Appliances ≤ 10kBtu/hr (3 kw) & ≤ 50 kBtu/hr (15 kw) • 12 in. (30 cm) Appliances > 50 kBtu/hr (15 kw)
C	Clearance to permanently closed window	.	.
D	Vertical clearance to ventilated soffit, eaves, or overhang	.	.
E	Clearance to unventilated soffit, eaves, or overhang	.	.
F	Clearance to outside corner	.	.
G	Clearance to inside corner	.	.
H	Clearance to each side of center line extended above meter/regulator assembly	.	36 in. (91 cm) within a height 15 ft. (91 cm) above the meter/regulator assembly
I	Clearance to service regulator vent outlet	.	36 in. (91 cm)
K	Clearance to non-mechanical air supply inlet to building or the combustion air inlet to any other appliance	Same clearance as row B	
J	Clearance to forced air inlet into a building	36 in. above if within 10 ft. horizontally	6 ft. (1.83 m)
L	Clearance above paved sidewalk or paved driveway located on public property	7 ft.	7 ft. (2.13 m)
M	Clearance under deck, veranda, porch, or balcony (open on three sides)	12 in.	24 in. (60 cm)

* For up to date clearances reference the most recent ANSI Z223.1/NFPA 54 or CGA-B149. For clearances not specified in ANSI Z223.1/NFPA 54 or CGA-B149, please use clearances in accordance with local installation codes and requirements or gas supplier.

HORIZONTAL TERMINATION CONFIGURATIONS

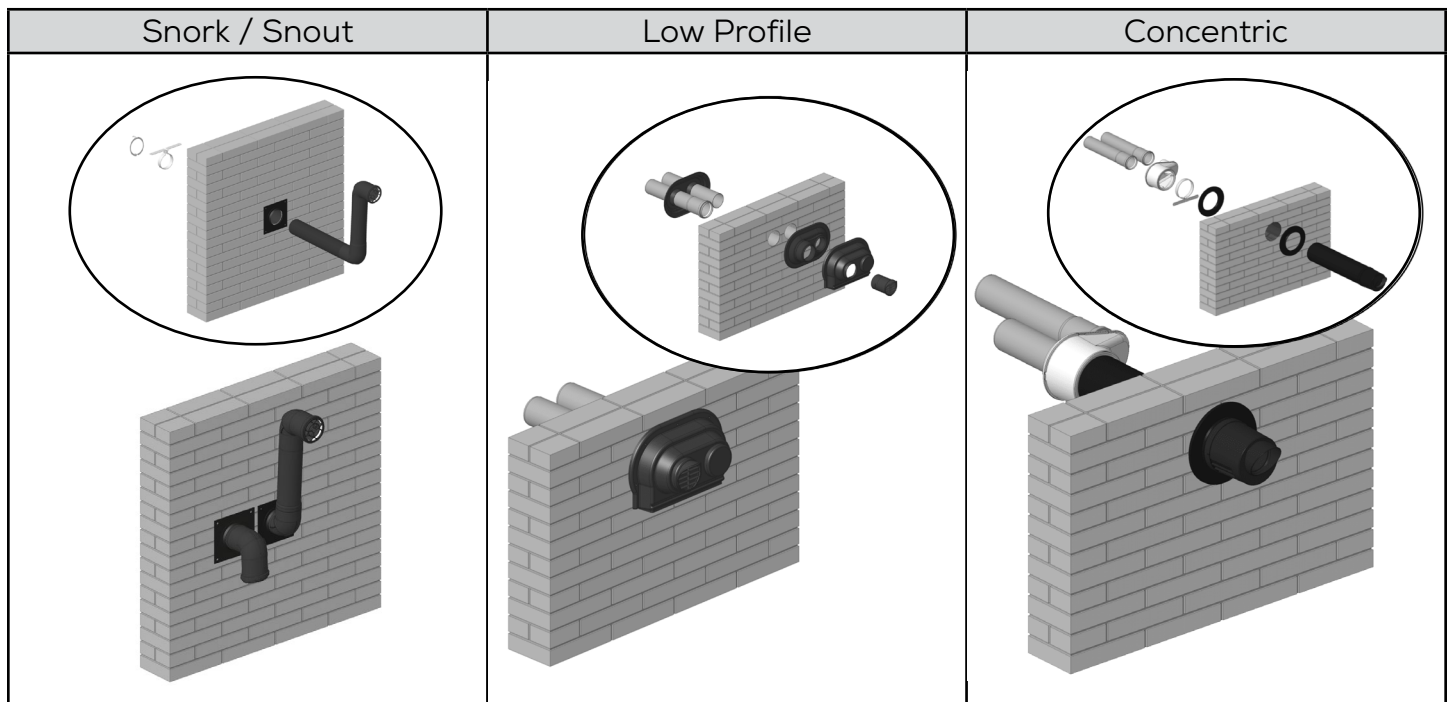

INNOFLUE® FLAME & SMOKE SPREAD RATING ASSEMBLY INSTRUCTIONS

InnoFlue® meets flame spread index and smoke developed index of <25 / <50 per UL-723, ASTM E-84 and ULC-S102.2 when wrapped with one of the following UL-723, ASTM E-84 or ULC-S102 listed material designed for use with plastic piping.

MATERIAL: Knauf Atmosphere Duct Wrap with ECOSE® Technology, 3M™ Fire Barrier Plenum Wrap 5A+, Unifrax FyreWrap® 0.5 Plenum Insulation.

Generic installation instructions are included. **Please follow the specific pipe wrap manufacturer's installation instructions.**

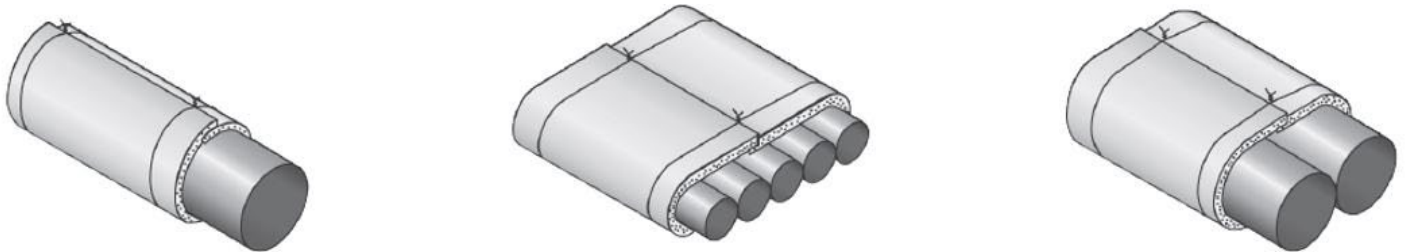

INSTALLATION INSTRUCTIONS

- Follow Centrotherm's InnoFlue® standard installation instructions.
- Vent supports are installed after the pipe has been wrapped.
- Install Wrap with facing to the outside.
- Butt all insulation joints firmly together. Longitudinal seam of the vapor retarder must be overlapped a minimum of 2" (51 mm). A 2" (51 mm) tab is provided for the circumferential seam and must be overlapped.
- Where vapor retarder performance is necessary, all penetrations, joints, seams and damage to the facing should be sealed with an FSK, PSK or foil tape or glass fabric and mastic prior to system startup.
- Pressure sensitive tapes should be a minimum of 3" (76 mm) wide and be applied with moving pressure using an appropriate sealing tool.
- Closure systems should have a 25/50 F.H.C. per UL 723.
- Unfaced Duct Wrap should be overlapped with a minimum of 2" (51 mm) and secured with a wire or banding system. Care must be taken to avoid damaging the duct wrap. Refer to diagram for butt-joint method

INNOFLUE® FIRE RATED WALL/CEILING PENETRATION ASSEMBLY

InnoFlue® Single Wall Polypropylene Vent Systems can be used in areas that require a one or two hour fire rating per ASTM E814, UL 1479 or ULC S115 when used with a listed passive fire protection system. Approved passive fire protection system manufacturers include PFP Partners and 3M. The Passive Fire Protection System Manufacturer's installation instructions should always be followed.

PFP PARTNERS:

InnoFlue® 2" through 6" diameter single wall venting has been tested and listed with PFP Partners Passive Fire Stopping Products for a 2 hour fire rating

Passive Fire Protection Partners

1412 Derwent Way
Delta BC, Canada V3M-6H9

PHONE: (800) 810-1788

EMAIL: firestop@firesstop.com

SINGLE PENETRATIONS W/ PFP PARTNERS

Horizontal (Floor/Ceiling)

Test Standards: ASTM E-814, UL 1479, ULC S115

Test Furnace Internal Positive Pressure Differential – 50 Pa (0.2 in. of Water)

Penetrating Material & Size	Max. Hole Size	Annular Space	Fire "F" Rating	Fire/Hose "FH" Rating	Temp Rating "FTH" Rating
InnoFlue® SW 2" - 6" (O.D.)	8" (203 mm)	1/8" - 1" (3 - 25 mm)	Up to 2 Hr	Up to 2 Hr	Up to 2 Hr

1.	Penetrating Item	InnoFlue® SW 2" through 6" vent lengths can be Centered or offset in hole, see table above. Single penetrations only, maximum hole size not to exceed table above.
2.	Floor/Wall Assembly	Code conforming 2 hour rated floor or wall assembly having a min. nominal 4 1/2" (115mm) thick lightweight or normal weight concrete or hollow-core concrete. Wall may also be constructed of nominal 8" (203mm) thick concrete blocks (filled or unfilled).
3.	InnoFlue® Covering Material	Friendly Feel® Duct Wrap with ECOSE® Technology, 3M™ Fire Barrier Plenum Wrap 5A+, Unifrax FyreWrap® 0.5 Plenum Insulation or equivalent fiberglass Insulation with foil - Single layer of 1/2" (12 mm) thick fiberglass insulation installed as per third party agencies Flame Spread and Smoke Development listed installation instructions. Insulation to be tightly butted to top and bottom of collar for both floor or wall assemblies. All seams longitudinal and transverse joints to be sealed with min 2 inch (51mm) wide aluminum foil tape.
4.	Intumescent Strip	PFP Partners - WS1 Wrap Strip* - Nominal 1/8" (3 mm) thick intumescent material supplied in 2" (50mm) wide strips. Min 1 layer of strip to be wrapped tightly round InnoFlue and fastened in place with aluminum foil tape. Wrap strip to be flush with bottom surface of floor or both sides of the wall.
5.	Mineral Wool Insulation	Filler material, mineral rock wool insulation with a minimum density of 4-6 PCF (68 kg/m3) compressed a minimum of 25% into the annular space at a minimum depth of 2" (51mm) on each side of the floor or wall assembly. Recess filler material 1/2" (13mm) for sealant placement, not required for wall assemblies. For walls, filler material to be flush with both sides of the assembly.
6.	Fire Rated Sealant	PFP Partners - Firestop 3600EX*, 4100NS*, 4100SL*, or 4800DW* installed at a minimum thickness of 1/2" (13mm) within the annulus on top surface of floor assembly, not required for wall assemblies. On 0 - 1/4" (0 - 6 mm) annular spaces, a 1/2" (13 mm) diameter fillet bead must be placed around InnoFlue® Vent System.
7.	Plastic Pipe Collar	PFP Partners - Plastic Pipe Collar* (PPC) specifically sized for diameter of InnoFlue. PPC secured to floor/ceiling assembly or wall assembly using 1/4" (6mm) diameter by 1-1/4" (32mm) long steel masonry anchors over fender washers. For walls, the system shall be symmetrical, with PPC installed on each side of the assembly and fixed in the manner as described for floor penetrations.

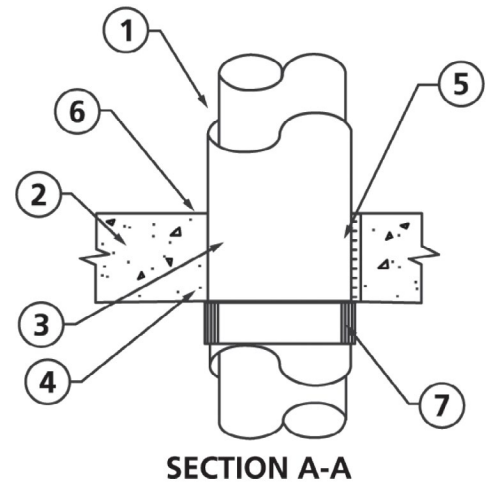
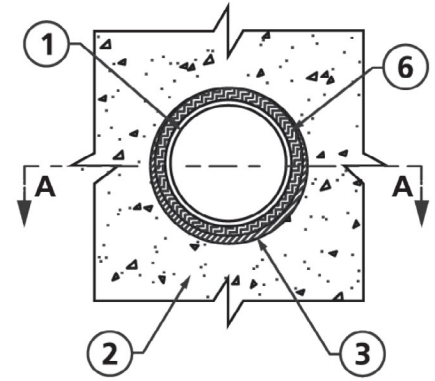

3M™:

InnoFlue® 2" through 4" diameters can be used with 3M™ Fire Protection Products to achieve 1 or 2 hr fire rating. Engineering Judgments for 2 hour fire ratings are available from 3M™ for 6" through 12" diameter InnoFlue® Single Wall Vent Systems. Contact Centrotherm or 3M™ for more information on commercial diameter fire ratings.

Ryan D. Fenstermaker

3M Building & Commercial Services / Fire Protection Products

Mobile: 732.921.1503 | Fax: 732.432.0616

r Fenstermaker@mmm.com

SINGLE PENETRATIONS W/ 3M™:

Horizontal (Floor/Ceiling)

Test Standards: ASTM E- 814, UL 1479, ULC S115-M05

Penetrating Material & Size	Max. Hole Size	Fire "F" Rating	Fire/Hose "FH" Rating	Temp Rating "FTH" Rating
InnoFlue® SW 2" - 12" (O.D.)	14" (356mm)	Up to 2 Hr	Up to 2 Hr	Up to 2 Hr

1.	Penetrating Item	InnoFlue® SW 2" through 12" vent lengths can be centered or offset in hole, see table above. Single penetrations only, maximum hole size not to exceed table above.
2.	Floor/Wall Assembly	Code conforming 2 hour rated floor or wall assembly of concrete or gypsum.
3.	InnoFlue® Covering Material	3M™ Fire Barrier Plenum Wrap 5A+ – Single layer of 1/2" (12 mm) thick fiberglass insulation installed per third party agencies Flame Spread and Smoke Development listed installation instructions. Insulation to be tightly butted to top and bottom of collar for both floor or wall assemblies. All seams longitudinal and transverse joints to be sealed with min 2 in. (51mm) wide aluminum foil tape.
4.	Intumescent Strip	3M™ – FS-195+ Wrap Strips: Tightly wrap the proper number of FS-195+ Wrap Strips around InnoFlue foil side out. Secure with tape or tie wire. Make sure FS-195+ Wrap Strip or PPD butts securely against the concrete with a 3/16" minimum overlap over the edge of the penetrating opening. When using more than one wrap, stagger the butted seams.
5.	Plastic Pipe Collar	3M™ – RC-1 Restricting Collar: Remove enough RC-1 Restricting Collar to make one wrap around the applied FS-195+ Wrap Strip with a minimum 1" overlap. Bend the mounting tabs away from the pipe at right angles, flush with the bottom floor surface. Warning: Edges of RC-1 Restricting Collar are sharp. Handle with care. Tightly secure the RC-1 Restricting Collar around the pipe with a steel hose clamp centered on the RC-1 Restricting Collar assembly. Two bands of 16 gauge steel tie wire placed ½ from the ends of the RC-1 Restricting Collar assembly may be used instead of the hose clamp. Secure the collar to the slab with ¼" x 1 ½" masonry fasteners. Use 1 ¼" diameter fender washers on the mounting tabs.
6.	Fire Rated Sealant	3M™ – CP 25WB+ Caulk: Seal the system with ¼" bead of 3M™ Fire Barrier CP 25WB+ Caulk or Moldable Putty+ at the concrete and collar assembly interface.

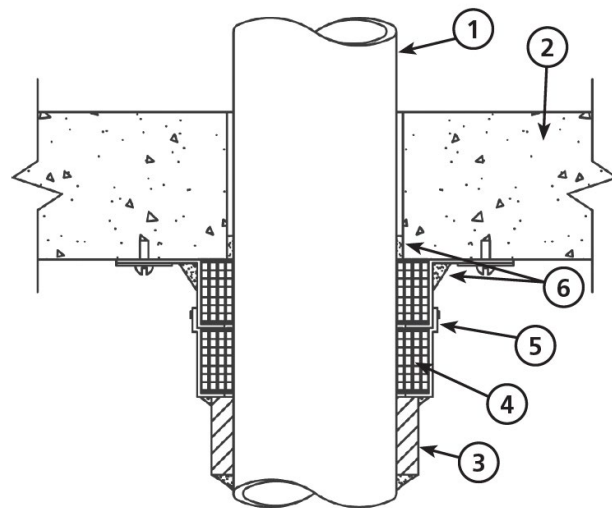

BASIC CONCENTRIC INSTALLATIONS INSTRUCTIONS

JOINT CONNECTION

- Vent connections must be firmly pressed together so that the gaskets form an airtight seal.
- To ensure optimum joint connection, secure with two #8 x 1/2" self-tapping screws provided. Screw through pre-drilled holes in metal female socket.
- Secure the vent to the wall or ceiling with support clamps or perforated hanger iron.

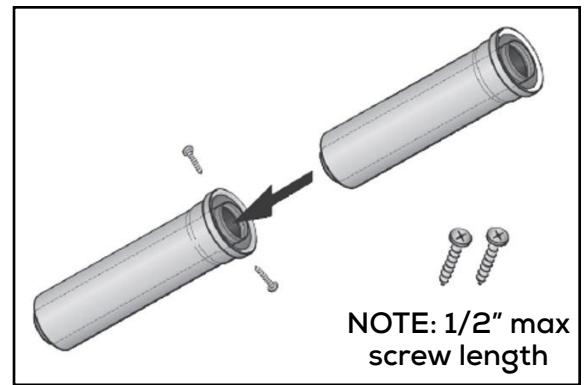

CONDENSATE MANAGEMENT

- Horizontal vent lengths must pitch a minimum of 3° or 5/8 in/ft to the appliance.

NOTE

See exception under Condensate on Page 4.

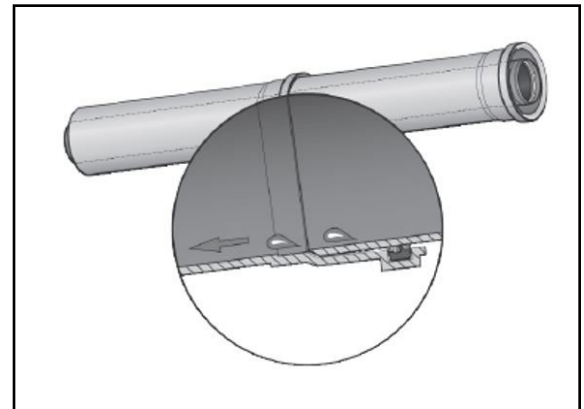

APPLIANCE CONNECTION (FEMALE APPLIANCE TOP)

- Insert the male end of a vent component into the female appliance top.

NOTE

Certain appliances may require appliance adaptor

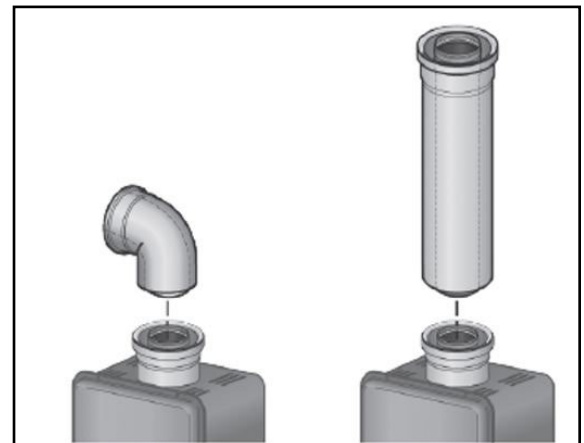

SHORTENING OF VENT EXTENSIONS (FEMALE APPLIANCE TOP)

- The inside pipe should always extend 0.4" (10 mm) beyond the white outside pipe on the male end of the vent extension.
- Always cut the male end of the vent pipe extension. Do not attempt to cut the female end.
- When cutting to size outer vent lengths overlap by 2" (50.8mm).
- Deburr both air intake (outer) and exhaust (inner). Failure to do so may result in gasket damage.
- Remove debris from inside the pipe prior to assembly

⚠ WARNING

Improper installation of vent system and components, or failure to follow all installation instructions, can result in property damage or serious injury.

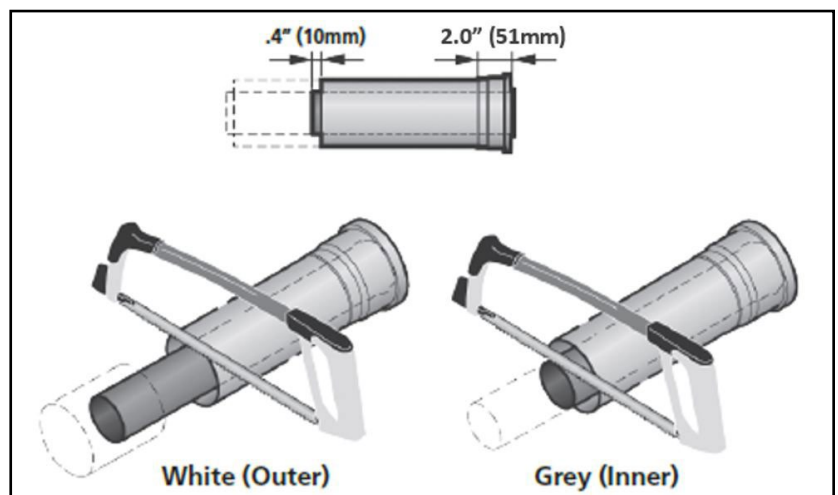

CONCENTRIC ADAPTORS

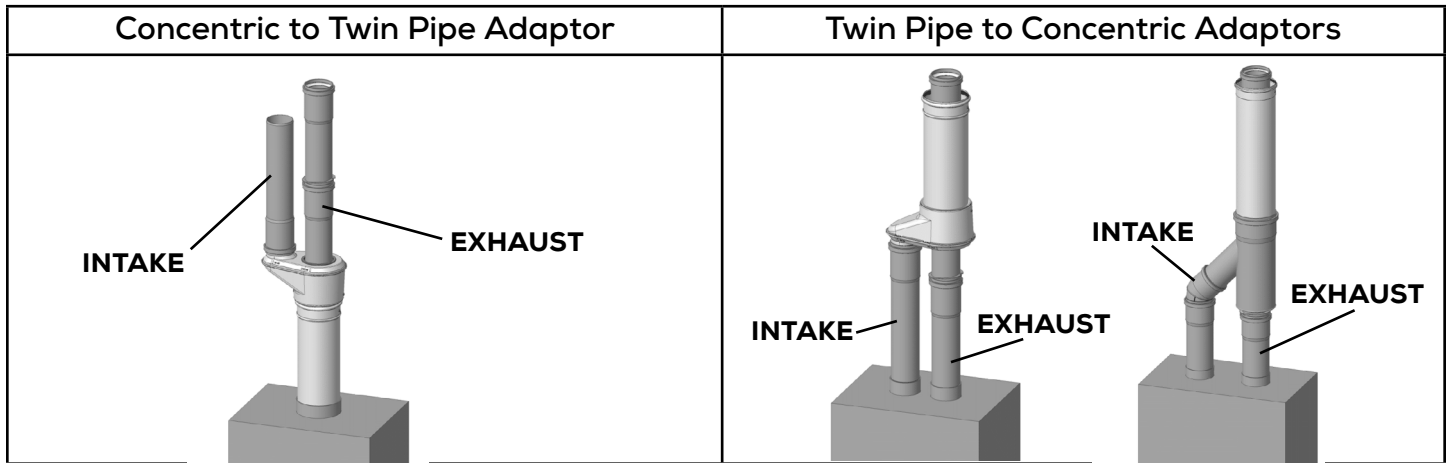

*Reversible adaptors are available in the 2"/4" & 3"/5" sizes

HORIZONTAL CONCENTRIC VENT SYSTEM

IDENTIFY THE VENT LOCATION

- Place the 87° Vent Pipe Elbow on the appliance.
- Mark position on wall taking into account 3° pitch.
- Or use template provided with appliance.
- Cut hole, covering the top of the appliance to prevent debris from entering

NOTE

Cover the top of the appliance to prevent debris from entering when cutting

MEASURE DIMENSION TO FIT

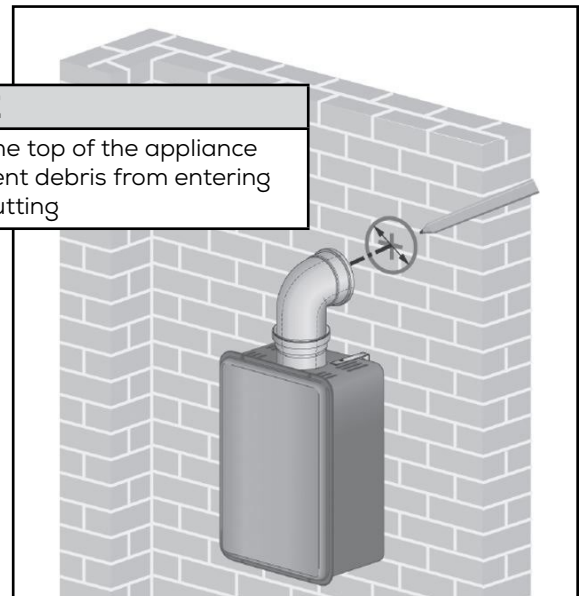
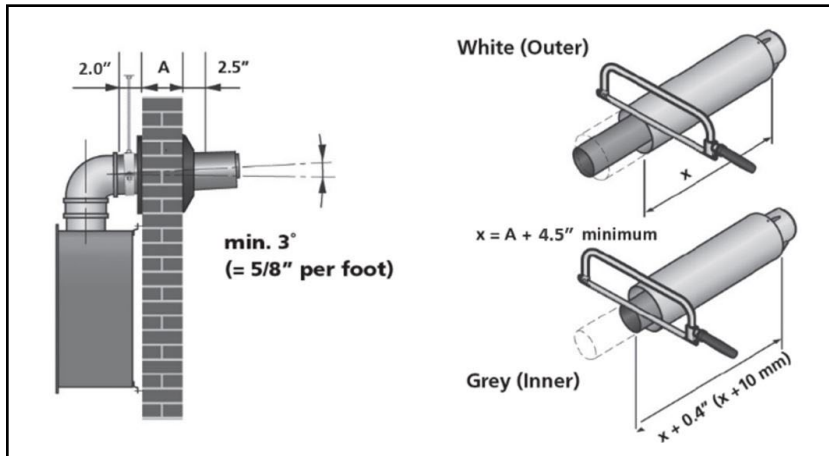

NOTE

First place inner wall plate to slide terminal through

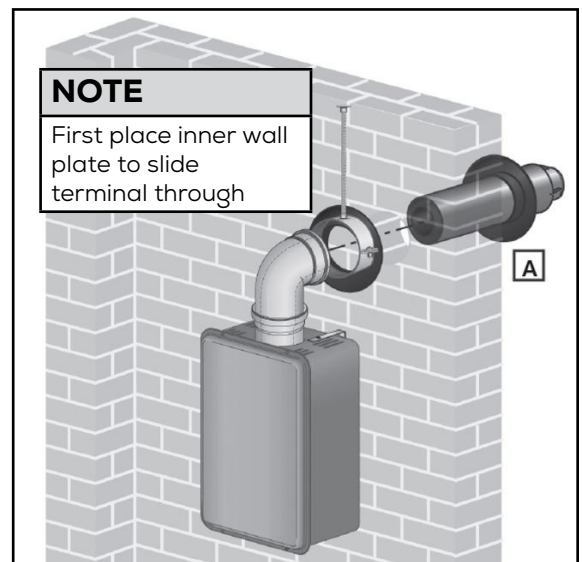

Reference Page 5 of these installation instructions for acceptable pitch direction.

FINAL INSTALLATION OF THE VENT SYSTEM

- After cutting the appropriate length, position the Wall Plate (A) and slide the Horizontal Termination through the hole in the wall. Position the Wall Plate around the male end of the Termination.
- Slide the male end of the Termination into the 87° Vent Pipe Elbow.
- Secure the system with the supplied Termination Support Clamp.
- Seal the gaps between the wall and the vent.

VERTICAL CONCENTRIC VENT SYSTEM

IDENTIFY THE VENT LOCATION

- Determine the location where the roof discharge terminal will be installed.
- Taking the angle of the roof into account, cut the hole with a dimension that allows the vertical discharge roof terminal to be installed.

CUT TO FIT

- The terminal can be shortened by cutting both the inside and outside pipes. See basic Concentric installation instructions for shortening.
- Deburr both air intake (outer) and exhaust (inner). Failure to do so may result in gasket damage.

MOUNTING THE VENT SYSTEM

- Vent connections must be firmly pressed together so that the gaskets form an airtight seal.
- Secure the system with the supplied Termination Support Clamp.

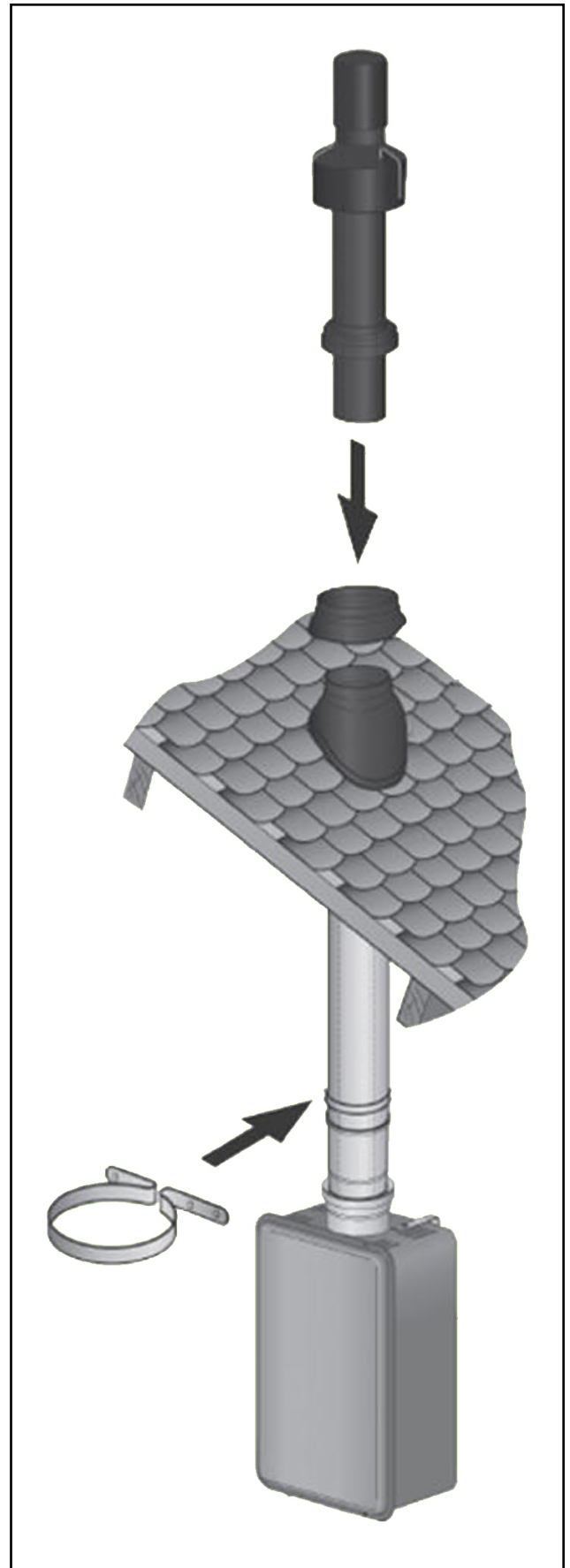
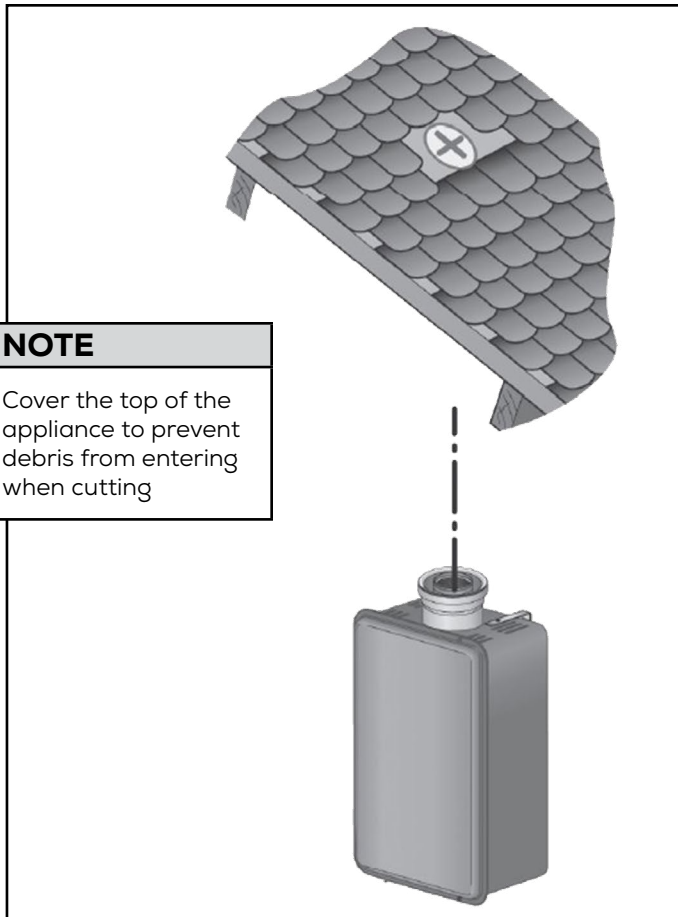



Centrotherm

solutions beyond

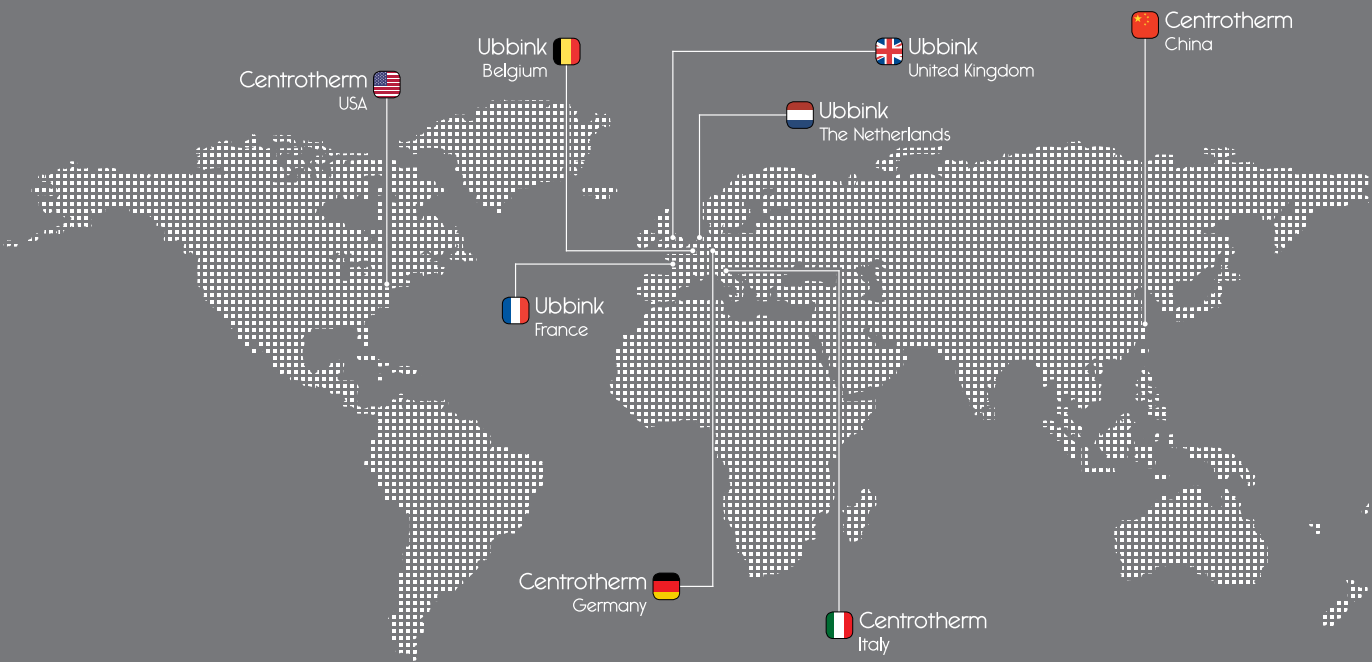

Ubbink Netherlands	www.ubbink.nl
Ubbink Belgium	www.ubbink.be
Ubbink France	www.ubbink.fr
Ubbink United Kingdom	www.ubbink.co.uk
Ubbink International	www.ubbink.com
Centrotherm Germany	www.centrotherm.com
Centrotherm Italy	www.centrotherm.it
Centrotherm U.S.A	www.centrotherm.us.com
Centrotherm China	www.centrotherm-china.com
	www.ubbink-centrotherm.com

NORTH AMERICA

Centrotherm
Toll Free: 877 434 3432
Fax: 518 618 3166
info@centrotherm.us.com
www.centrotherm.us.com



250000000623
CDID0125